

WARNING

Read Before Printing Template

The In-Dash Template in this document is accurate only if your printer is set up to print it actual size. Do this by unchecking the "Fit to page" option in the printer menu. To do this:

1. Click File|Print.
2. In the Print Dialog Box, uncheck the "Fit to page" option. *(This is located below the Properties button in the top right corner of the print dialog box.)*
3. Click OK to print.

Read Before Using Template

Carefully check the print with a ruler. Check it for both horizontal and vertical accuracy by measuring the distance between the mounting holes.

Dimensions are first given in millimeters and then inches (in parenthesis).



FM-4 In-Dash Adapter Kit Installation Instructions

This adapter kit is designed for in-dash mounting the following products: Lowrance® X51; Eagle® FishEasy™ 2, FishEasy™ 2 T, TriFinder™ 2.

Please read all instructions before proceeding. **NOTE:** Recommended tools for this job include: jig saw, drill, 1/2" drill bit, 1/8" drill bit, 1/4" nut driver or adjustable wrench.

1. Select the desired mounting location. Make certain there is enough room behind the dash to attach the power and transducer cables. The case is approximately 1.5" (38.1mm) deep behind the mounting surface. ***The maximum dash thickness that can be used with this mounting kit is 0.75" (19mm).*** Carefully measure the dash thickness before cutting any holes.
2. Tape the template on page 3 of this manual to the dash. Begin the cutout by drilling the four corner holes and the two side holes where indicated on the template. For the corner holes, use a 1/2" drill bit. For the side holes, use a 1/8" drill bit.
3. Slip your saw blade into one of the corner holes and then cut along the lines from hole to hole. Be careful when working around the corners and the two side holes, because there is little room for error. When you are finished, you should have a dash cutout that is 4.68" wide by 4.40" tall (119mm x 112mm).
4. Slide the gasket supplied with the kit over the back of the case.

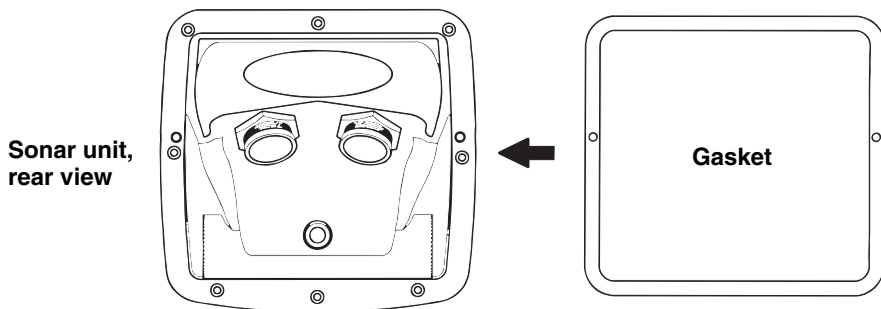

Slide gasket over back of case.

5. Install the two threaded rods in the back of the unit. Do not over-

tighten or damage to the case may occur.

6. Place the unit into the dash cutout.
7. Push the self-retaining screw spacers onto the threaded rods on the back of the unit.

**Unit side view,
mounted in dash**

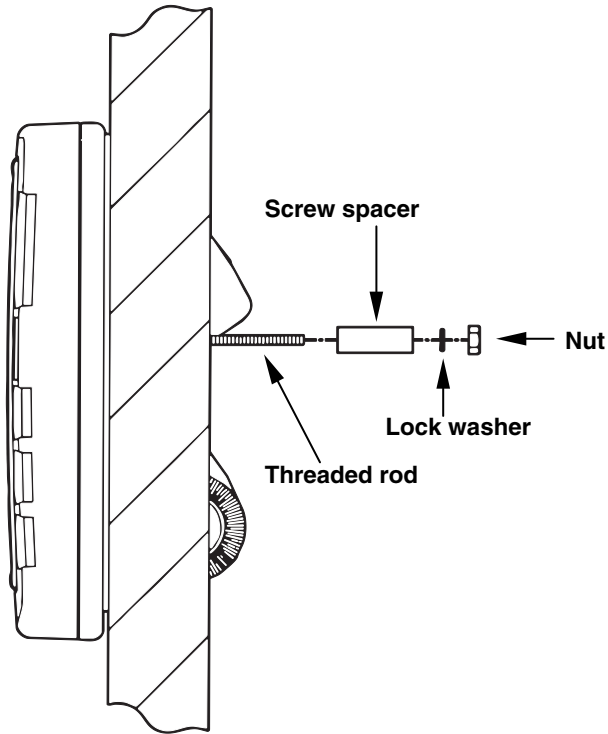

**Push screw spacers onto threaded rods,
followed by lock washers and nuts.**

7. Next, push the lock washers onto the threaded rods and secure them with the nuts provided. Route the power and transducer cables to the unit and it's ready for use.

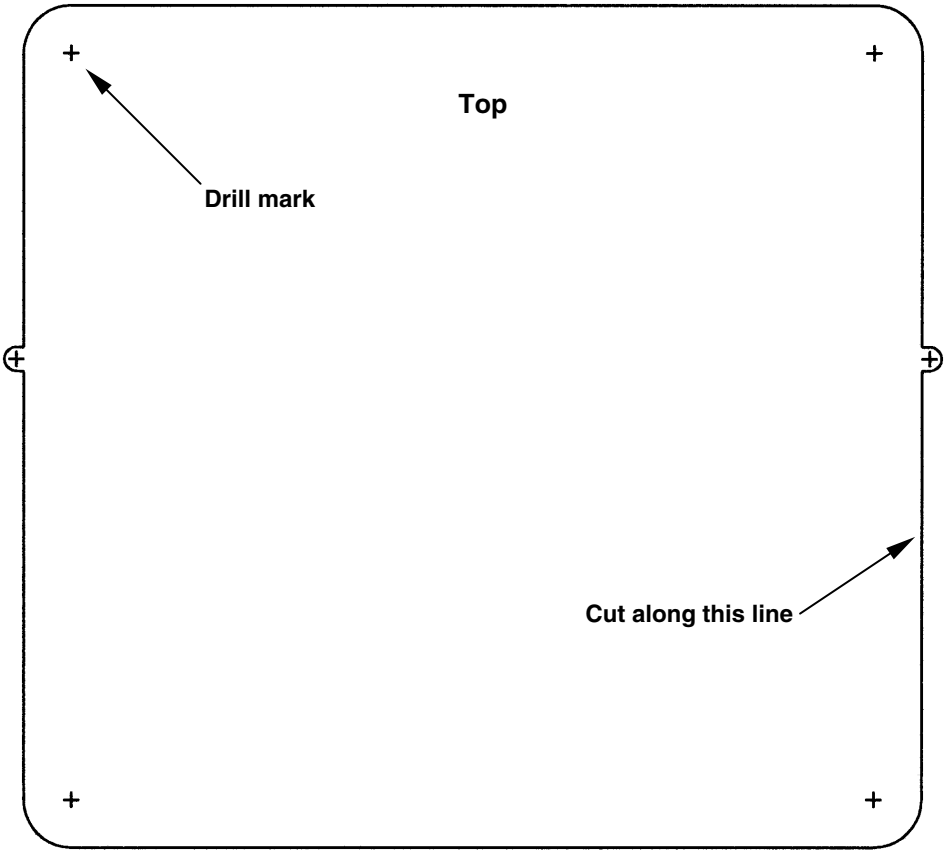

**FM-4 dash cutout template. Tape this page to dash.
Drill holes where indicated, then cut along the line.
See text for drill diameters.**

How to Obtain Service...

...in the USA:

Contact the Factory Customer Service Department. Call toll-free:

For Lowrance: 800-324-1356. For Eagle: 800-324-1354

8 a.m. to 5 p.m. Central Standard Time, M-F

Lowrance Electronics and Eagle Electronics may find it necessary to change or end their shipping policies, regulations and special offers at any time. They reserve the right to do so without notice.

...in Canada:

Contact the Factory Customer Service Department. Call toll-free:

800-661-3983

905-629-1614 (not toll-free)

8 a.m. to 5 p.m. Eastern Standard Time, M-F

...outside Canada and the USA:

Contact the dealer in the country where you purchased your unit. To locate a dealer near you, see the instructions in paragraph number 1 below.

Accessory Ordering Information

LEI Extras™, Inc. is the accessory source for sonar and GPS products manufactured by Lowrance Electronics and Eagle Electronics. To order Lowrance or Eagle accessories, please contact:

1) Your local marine dealer or consumer electronics store. To locate a Lowrance dealer, visit the web site, www.lowrance.com, and look for the Dealer Locator. To locate an Eagle dealer, visit the web site, www.eaglesonar.com, and look for the Dealer Locator. Or, consult your telephone directory for listings.

2) U.S. customers: LEI Extras Inc., PO Box 129, Catoosa, OK 74015-0129
Call toll free in the U.S., 800-324-0045, 8 a.m. to 5 p.m. Central Standard Time, M-F, or visit our web site www.lei-extras.com.

3) Canadian customers: Lowrance/Eagle Canada, 919 Matheson Blvd. E. Mississauga, Ontario L4W2R7 or fax 905-629-3118.

Call toll free in Canada, 800-661-3983, or dial 905 629-1614 (not toll free), 8 a.m. to 5 p.m. Eastern Standard Time, M-F.



Pub. 988-0147-44

Printed in USA 060502

© Copyright 2002
All Rights Reserved
LEI Extras, Inc.